

# SCREEN SEPARATOR PST



Optimal separation



Long service life

Easy cleaning process

SORTING OF GRAIN

**SCREEN SEPARATOR PST** is designed for sorting of grainy, dry, loose materials on the network system (small and coarse material) and cleaning with the air stream in the subsequent aspiration case with air recirculation (airborne dust and light dirt). It is used in pre-cleaning (P) and cleaning (C) sections of the mills, or for pre-cleaning grain in silos. For separation of metal particles the aspiration-board box is equipped with a permanent board magnet in inlet extension.

# SCREEN SEPARATOR **PST**

<b>PST</b>	Type marking of the machine – screen separator		
<b>100</b>	Size	Options type <b>100, 102, 120</b>	
<b>C</b>	Machine designation	<b>C</b> – cleaning	<b>P</b> - precleaning
<b>15</b>	Punching of upper sieves	3 – 25 mm	
<b>2,2</b>	Punching of bottom sieves	1,8- 3 mm;option 2,2=2,24x2,24 mm;option 0,6-3,15 mm	

MAIN TECHNICAL DATA								
Parameter		Unit, producer	PST 102		PST 100		PST 120	
			C	P	C	P	C	P
<b>Output</b>	<b>C-cleaning; P-precleaning</b>	t hr-1	7,5	30	15	60	30	120
<b>Input</b>		kW	2 x 0,55		2 x 0,55		2 x 1,1	
<b>Weight</b>		kg	510		745		1172	
<b>Aspiration air amount</b>		m <sup>3</sup> min <sup>-1</sup>			20			

Parameters of aspiration box	Unit	PAR 3	PAR 3	DUAL BOX
<b>Max. aspiration air consumption</b>	m <sup>3</sup> .min <sup>-1</sup>	10	10	20
<b>Pressure loss</b>	Pa	50 - 100		
<b>Input of aspiration box</b>	kW	1 x 4	1 x 4	2 x 4
<b>Input of worm conveyor and air device of aspiration box</b>	kW	1,1	1,1	1,1
<b>Weight of aspiration box</b>	kg	410	410	875

# SCREEN SEPARATOR **PST**

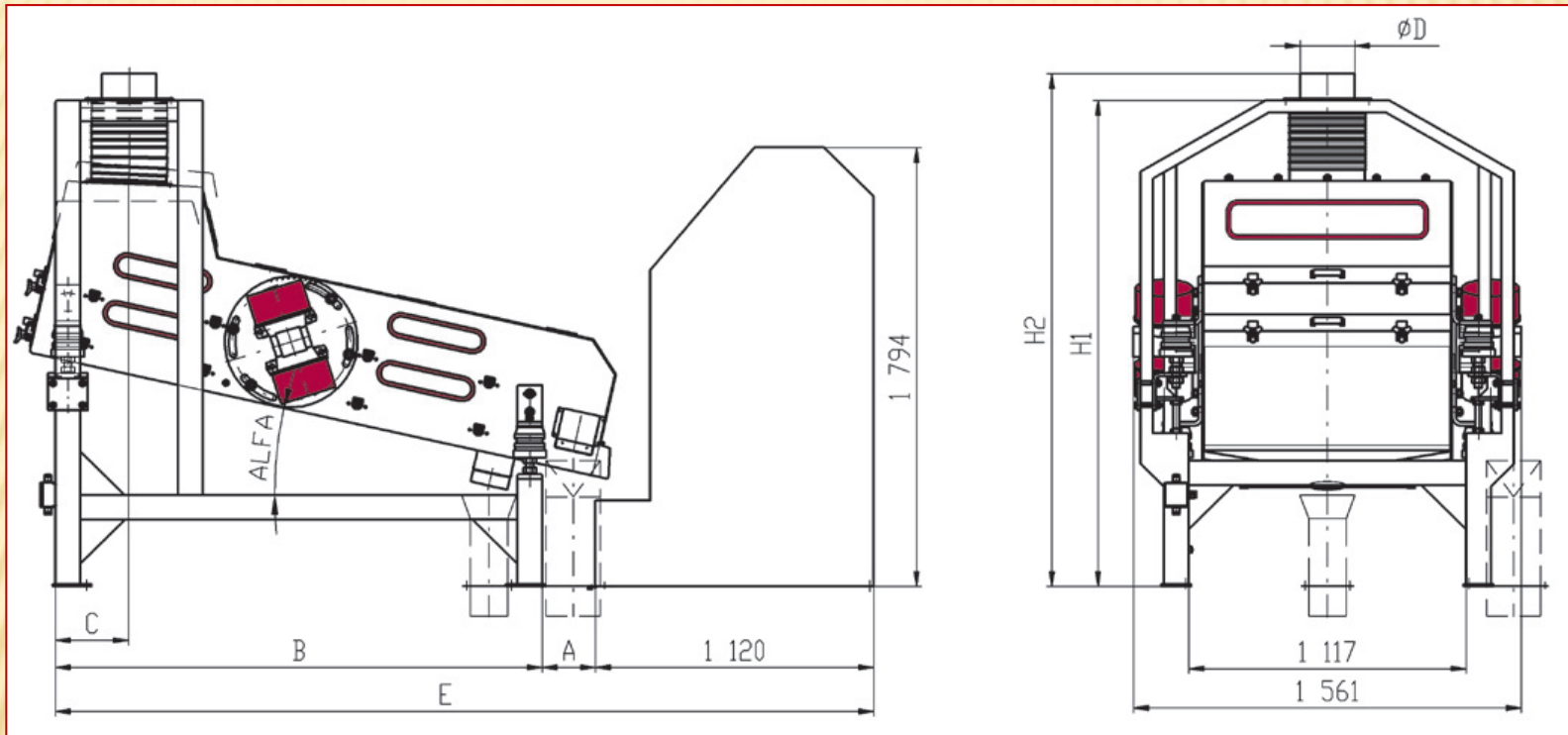

**PST 100**

Typ	A	B	C	ØD	E	H1	H2
PST 100 P	215	1 960	297	219	3 295	1 987	2 095
PST	237	1 989	246	152	3 346	1 863	1 942

P – precleaning

C – cleaning

# SCREEN SEPARATOR **PST**

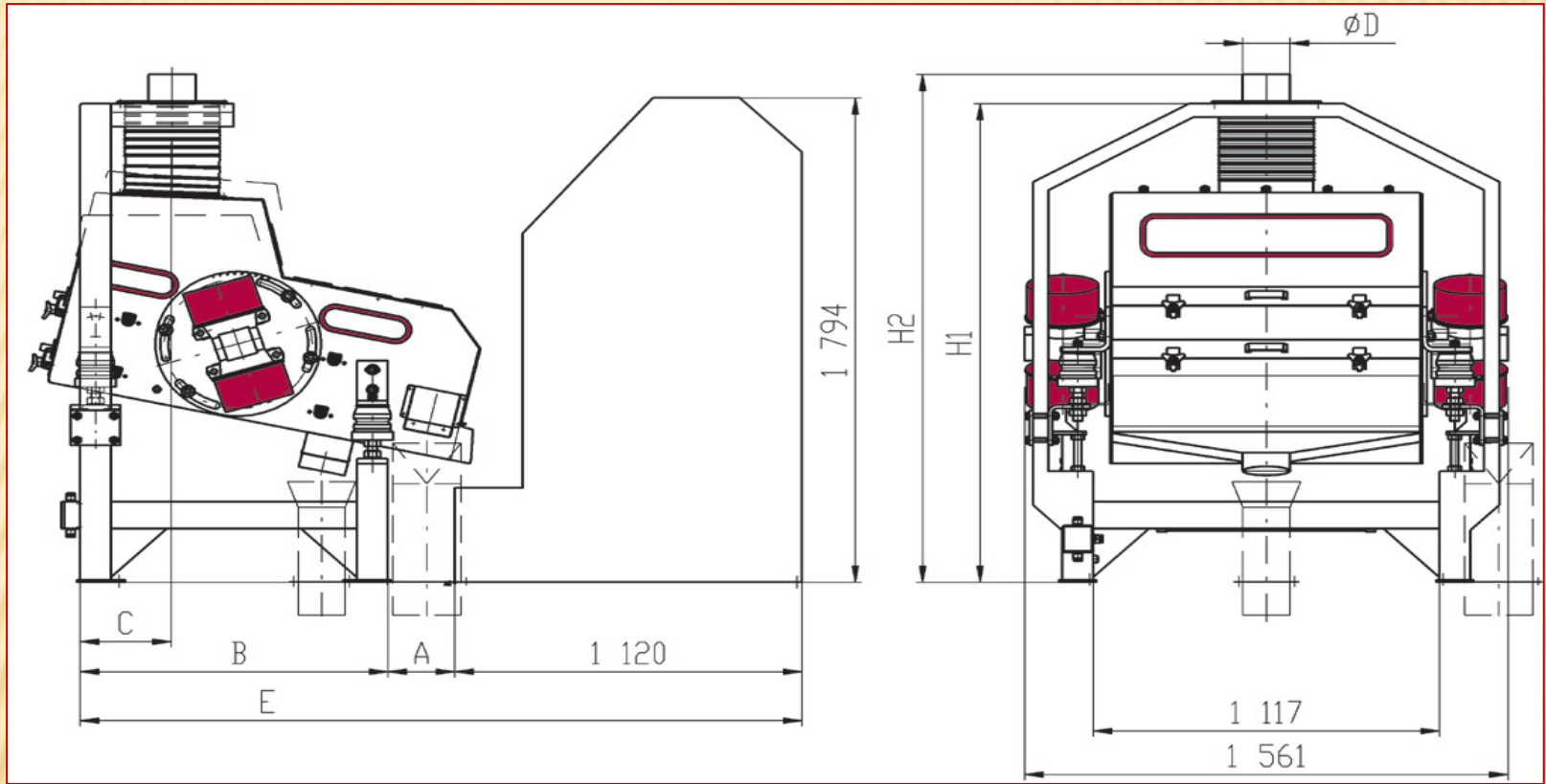

**PST 102**

Typ	A	B	C	$\varnothing D$	E	H1	H2
PST 102 P	215	992	297	152	2 329	1 773	1 881
PST	237	1 007	246	120	2 364	1 662	1 770

P – precleaning  
C – cleaning

# SCREEN SEPARATOR **PST**

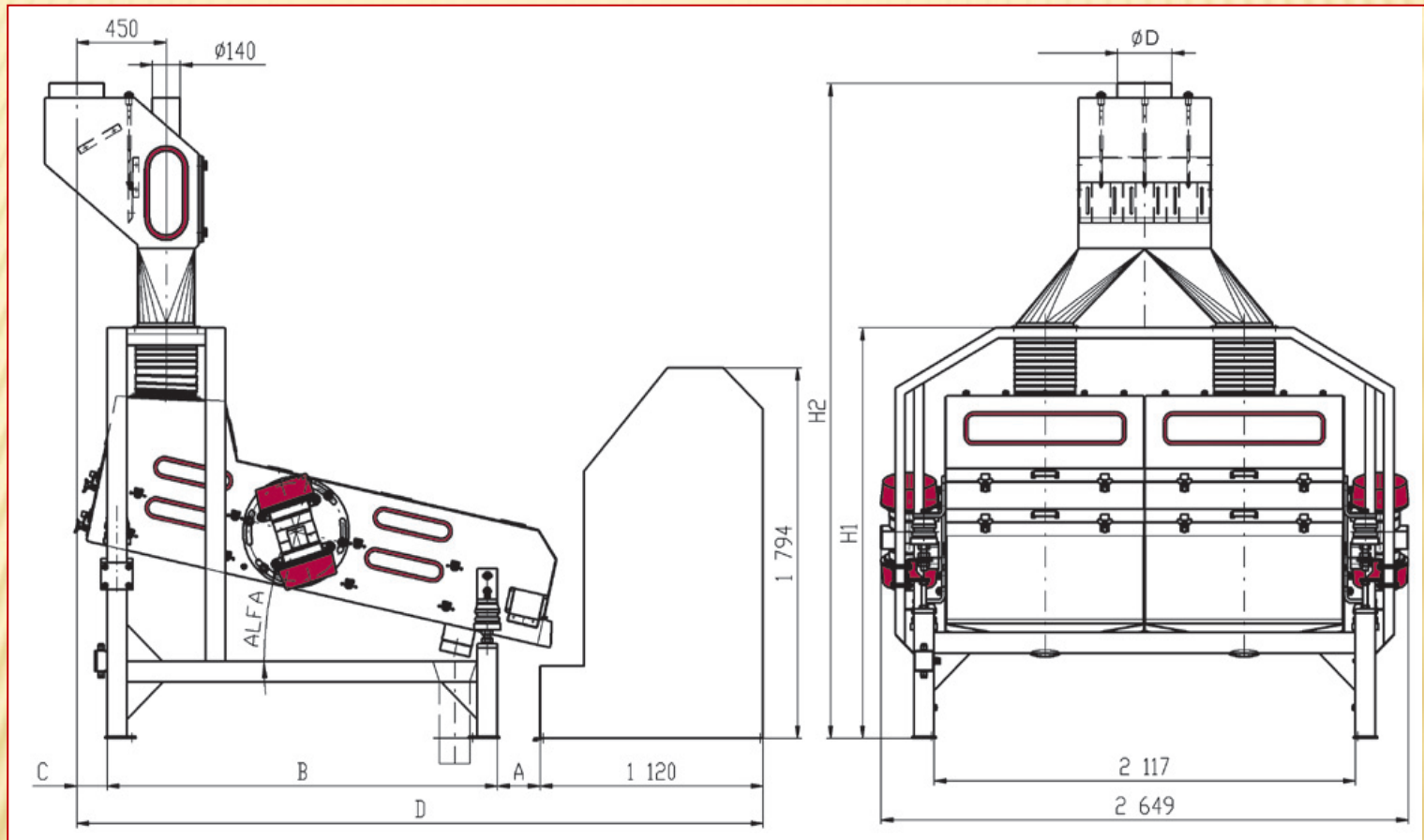

**PST 120**

Typ	A	B	C	̸D	E	H1	H2
PST 120 P	215	1 960	153	273	3 448	1 987	3 169
PST	237	1 989	204	273	3 550	1 863	3 045

P – precleaning  
C – cleaning

Dělnická 384  
530 00 Pardubice  
CZECH REPUBLIC

**Táňa Mičková**

tel.: + 420 775 200 898

**Roman Janovský**

tel.: + 420 728 332 250

e-mail: [torofa@email.cz](mailto:torofa@email.cz)

web: [www.torofa.cz](http://www.torofa.cz)