

# MICRODOSER PDM



Oneworm microdoser can be incorporated into production lines with a semi-automatic or auto-matic cycle. Used electronic controls allows switching on and off from the control computer production line. Operating the dispenser is easy and the equipment requires minimal maintenance.

Oneworm microdoser PDM is constructed in modular manner with various options stack size, the average dosing screws, type outlet etc., which can be combined in any way.

VOLUMETRIC DOSING OF RAW MATERIALS

**ONEWORM MIKRODOSER PDM 1** is designed to volume dose dry bulk non-stick substances with high precision dosing. Maximum granulation fed material may be 1 mm. Dosed amount can be continuously set and the operation of the dispenser. This equipment finds application in all fields where the need for precise volumetric dosing and especially in the food industry, chemical.

# MICRODOSER PDM

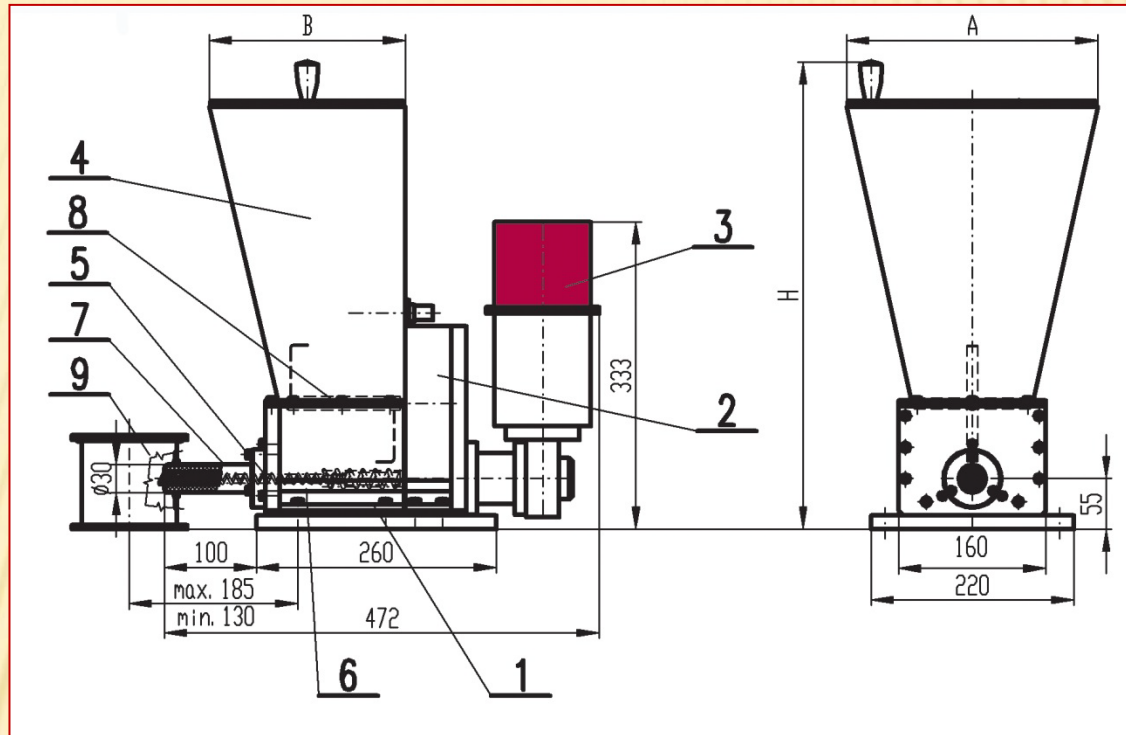

- 1 - basic set    2 - gear box    3 - drive  
 4 - bin        5 - worm        6 - inlay  
 7 - jet         8 - tedder      9 - outled

	A	B	H
<b>PDM 1.05</b>	222	181	417
<b>PDM 1-10</b>	272	211	503
<b>PDM 1-15</b>	322	242	582

Dimension		PMK 1
Maximum output	kg.h <sup>-1</sup>	0,12 – 15,5
Input	W	120 250
Number of rev. elektromotor	rpm	20 - 100
Range of rev. of dosing worms	rpm	20 - 100
Dosing worms diametres	mm	6, 8, 10, 12, 16, 20
Dosing accuracy	%	± 1
Weight	kg	20

Dělnická 384  
530 00 Pardubice  
CZECH REPUBLIC

**Táňa Mičková**

tel.: + 420 775 200 898

**Roman Janovský**

tel.: + 420 728 332 250

e-mail: [torofa@email.cz](mailto:torofa@email.cz)

web: [www.torofa.cz](http://www.torofa.cz)