

FLOW SIFTER PPS 2



STIR – AREA AND SIFT FLOUR

FLOW SIFTER PPS 2 is used to control sifting flour in mixing Section of the mills. The machine can be used for screening other dry bulk materials suitable physical properties. In inlet is brought flour, which is on the rotor under worm invasion transported into the interior sieve. Flour is thrown by the wings against the sieve and sieve openings expires plummeting. Impurities are then transported through the membrane into the overflow end.

FLOW SIFTER PPS 2

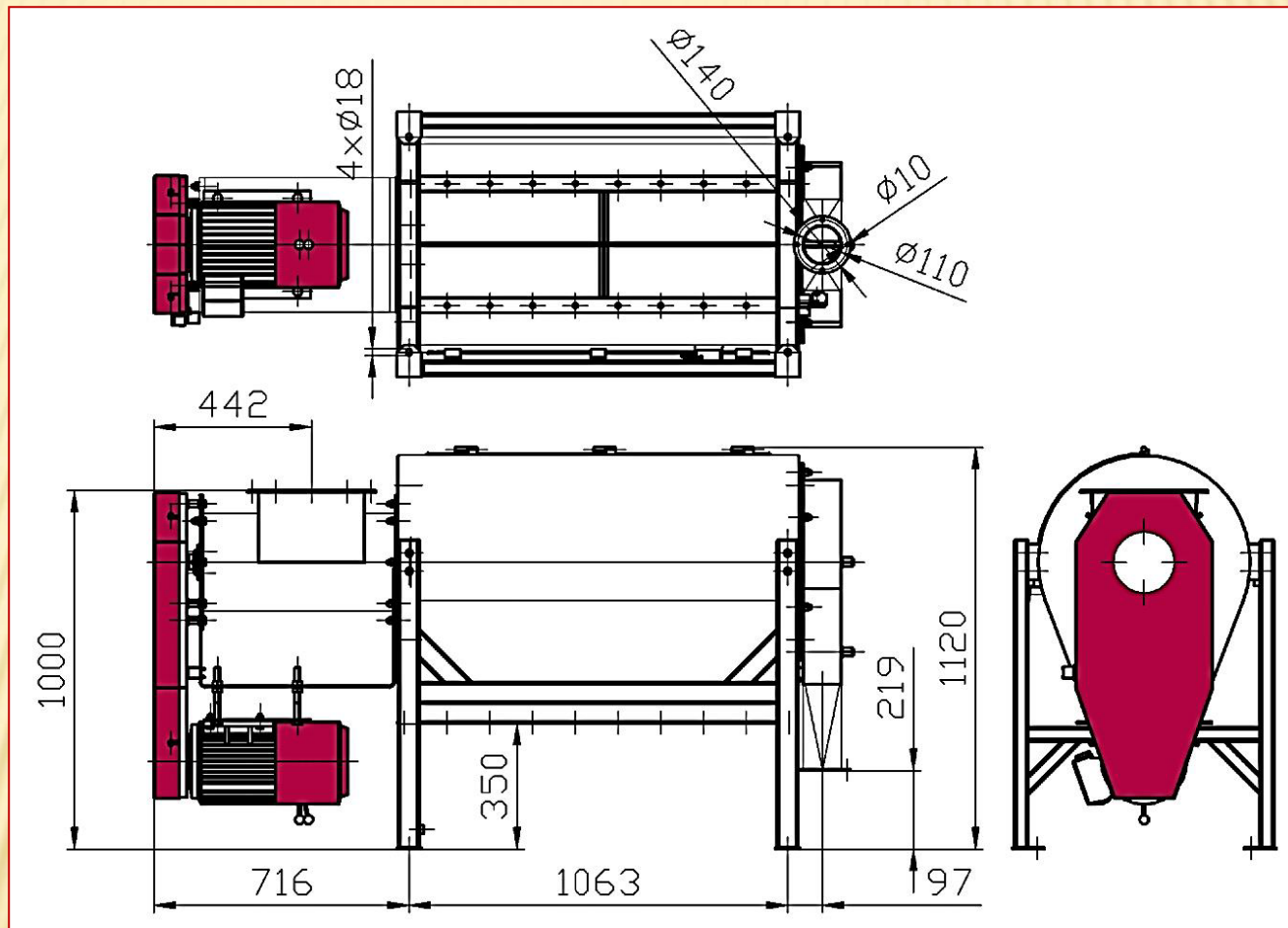

TYPE		PPS 2	
Output	Screen (perforated sheet $\phi 1,5$ mm)	t.h ⁻¹	10 – 12
	Screen (perforated sheet $\phi 3$ mm)	t.h ⁻¹	30
Weight		Kg	360
Rotor speed		rpm	515
Input		kW	4

Dělnická 384
530 00 Pardubice
CZECH REPUBLIC

Táňa Mičková

tel.: + 420 775 200 898

Roman Janovský

tel.: + 420 728 332 250

e-mail: torofa@email.cz

web: www.torofa.cz